



**Geo-Vista**

## High Build Rate Logging While Drilling System (HbuildLWD)

Rotary Steerable Unit-High Build Rate (RSU-B)

Wireless Measurement While Drilling-B (MWD-B)

Electromagnetic Propagation Resistivity-B (EPR-B)

Bi-directional Communication Power Module-B (BCP-B)

Battery Management Unit (BAT)

Pressure Unit While Drilling (PWD)

Pressure & Caliper Measurement While Drilling (PCD)

Dynamics While Drilling (DWD)

Caliper Corrected Neutron Porosity (CCN)

Rotary Azimuthal Density (RAD)

Azimuthal Resistivity While Drilling (ARD)

Acoustic While Drilling (AWD)

Ultrasonic Imaging While Drilling (UID)

Nuclear Magnetic Resonance

Imaging While Drilling (MRI)

Formation Tester While Drilling (FTD)

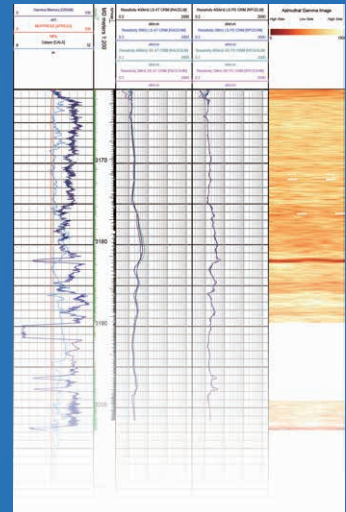
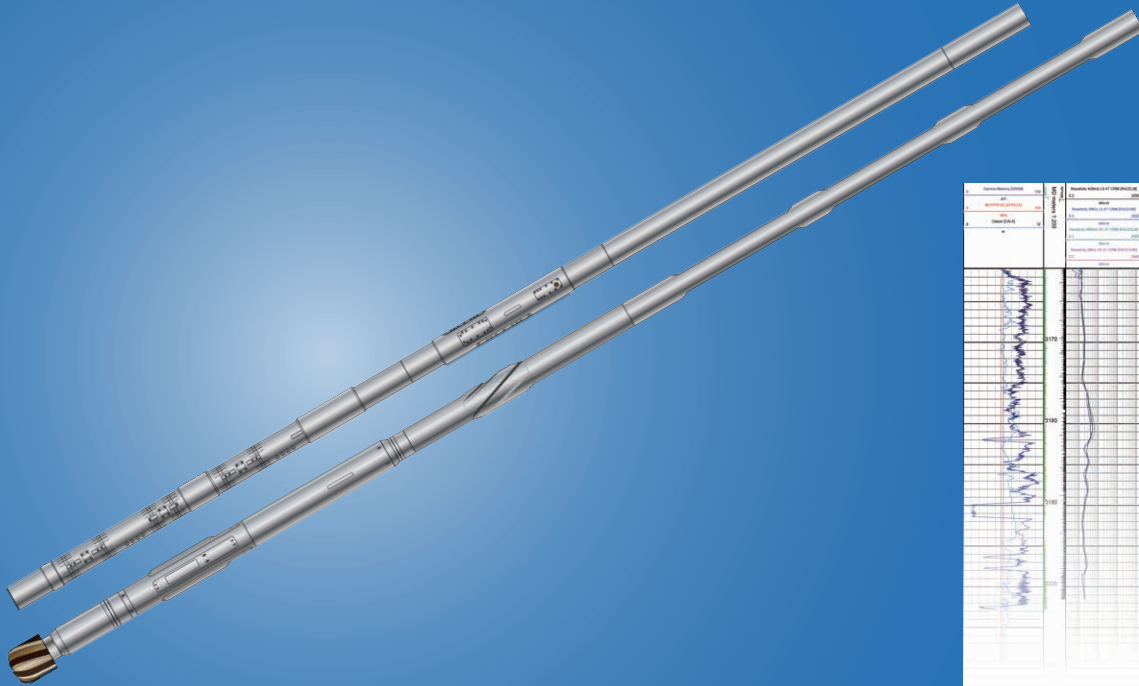

[www.RenheSun.com](http://www.RenheSun.com)

[www.geovista.cn](http://www.geovista.cn)



# High Build Rate Logging While Drilling System (HbuildLWD) 6.75 in.

**Geo-Vista**

## Applications

- Geosteering
- Automatically steering while drilling
- Well trajectory monitoring
- Provides Resistivity
- Provides Borehole Pressure and Caliper

## Benefits

- Continuous steering while rotating
- Minimized torque & drag
- Improved hole cleaning
- Higher ROP
- Reduced differential sticking
- Bit selection for performance
- Improved hole quality
- Time saving

## Features

- Build rate is 15°/100 ft. (15°/30 m).
- Provides Azimuthal Gamma Ray
- Provides Near Bit Inclination.

## Introduction

The high build rate (15°/100 ft.) geosteering system makes sure drill directional or horizontal wells by only one trip. Near bit inclination, azimuthal gamma ray, resistivity, caliper, pressure, vibration, etc are acquired at the same time.

## Components

- Stop Sub
- Bi-directional Communication Power Module-B (BCP-B)
- Battery Management Unit (BAT)(Optional)
- Pressure & Caliper Measurement While Drilling (PCD/PWD)
- Electromagnetic Propagation Resistivity-B (EPR-B)(Optional)
- Wireless Measurement While Drilling-B (MWD-B)
- High Build Rate Rotary Steerable Unit (RSU-B)

*Note: MWD-B includes Azimuthal Gamma Ray.*

## Specifications

Tool O.D. (Nominal)	6.75 in.
Hole Size	8-1/2 in. to 9-7/8 in. (216 to 251 mm)
Length (Nominal)	42 ft.-6.63 in. (12.97 m)
Weight	4,079 lbs. (1,850 kg)
Connections	Up:4 1/2 in. IF Box Down:4 1/2 in. Reg Box
Dogleg Severity	Max. Rotating 13°/100 ft. (13°/30 m) Max. Sliding 20°/100 ft. (20°/30 m)
Mud Flow Range	200-900 GPM

### Operating Specifications:

Max. Temperature	350°F (175°C)
Max. Pressure	20,000 psi (137.9 MPa)
Sand Content	Max. volume recommended<1%
Lost Circulation Material	Fine to medium nut plug
Pulsation Dampener	Recommended set to 1/3 stand pipe pressure
Data Acquisition	Mud pulse telemetry to surface and downhole memory
Telemetry Type	Positive pulse
Mud Pumps	Either duplex or triplex
Downhole RPM	± 80% max. deviation from the mean Operating rpm (e.g., 100 rpm: Operation Range=20-180 rpm)
Pulser Pressure Drop	Pressure drop dependent upon mud weight, flow rate, MWD tool valve gap, and data transmission rate.
DP at Bit	No restrictions
Mud Filter (Uphole)	Most sizes supplied
Full Survey Transmission	55 seconds from Pumps-On

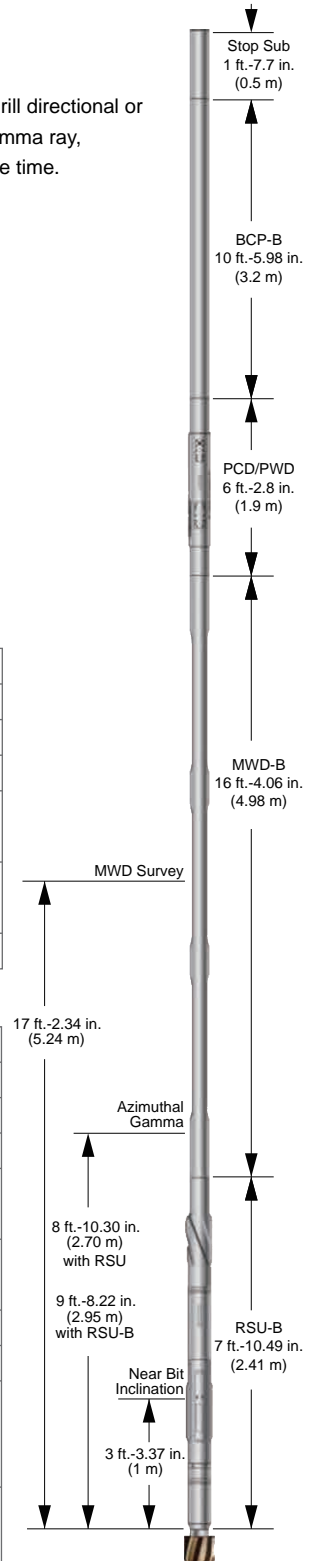



## Applications

- Geosteering
- Automatically steering while drilling
- Well trajectory monitoring
- Provides Resistivity
- Provides Borehole Pressure and Caliper

## Benefits

- Continuous steering while rotating
- Minimized torque & drag
- Improved hole cleaning
- Higher ROP
- Reduced differential sticking
- Bit selection for performance
- Improved hole quality
- Time saving

## Features

- Build rate is 10°/100 ft (10°/30 m).
- Provides Azimuthal Gamma Ray
- Provides Near Bit Inclination.

## Introduction

Geosteering with near bit inclination, azimuthal gamma ray and resistivity can get information for reservoir navigation. Adopt insert mode, different size (4.75 in./6.75 in./9.5in.) instrument can share insert probe, reduce the cost.

## Components

- Stop Sub
- Bi-directional Communication Power Module-B (BCP-B)
- Battery Management Unit (BAT)(Optional)
- Pressure & Caliper Measurement While Drilling (PCD/PWD)
- Electromagnetic Propagation Resistivity-B (EPR-B)(Optional)
- Wireless Measurement While Drilling-B (MWD-B)
- High Build Rate Rotary Steerable Unit (RSU-B)

*Note: MWD-B includes Azimuthal Gamma Ray*

## Specifications

Tool O.D. (Nominal)	4.75 in.
Hole Size	5-7/8 in. to 6-3/4 in. (150 to 172 mm)
Max. Temperature	350°F (175°C)
Max. Pressure	20,000 psi (137.9 MPa)
Length (Nominal)	50 ft.-4.72 in. (15.36 m)
Weight	3,617 lbs. (1,640 kg)
Connections	Up:3 1/2 in. IF Box Down:3 1/2 in. Reg Box
Dogleg Severity	Max Rotating 10°/100 ft. (10°/30 m) Max Sliding 30°/100 ft. (30°/30 m)
Mud Flow Range	125-350 GPM

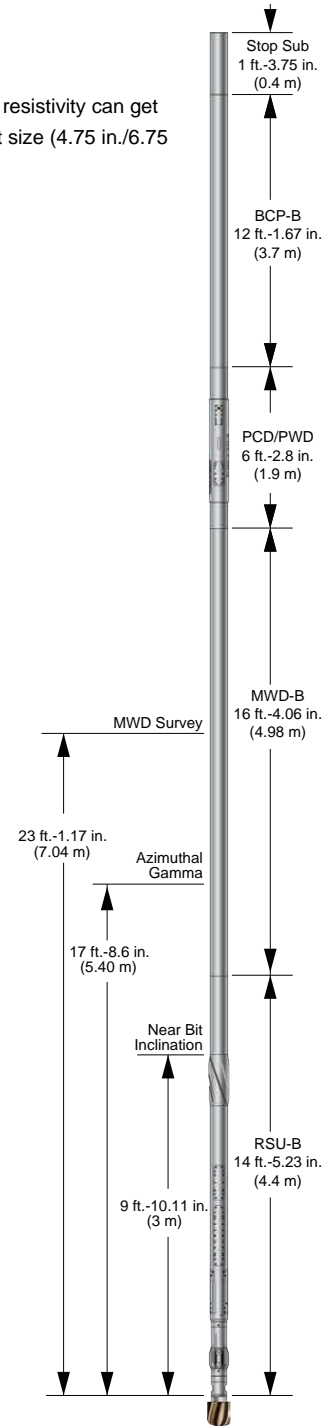



## Applications

- Geosteering
- Automatically steering while drilling
- Well trajectory monitoring
- Provides Resistivity
- Provides Borehole Pressure and Caliper

## Benefits

- Continuous steering while rotating
- Minimized torque & drag
- Improved hole cleaning
- Higher ROP
- Reduced differential sticking
- Bit selection for performance
- Improved hole quality
- Time saving

## Features

- Build rate is 10°/100 ft (10°/30 m).
- Provides Azimuthal Gamma Ray
- Provides Near Bit Inclination.

## Introduction

Geosteering with near bit inclination, azimuthal gamma ray and resistivity can get information for reservoir navigation. Adopt insert mode, different size (3.375 in./4.75 in./6.75 in./9.5in.) instrument can share insert probe, reduce the cost.

## Components

- Bi-directional Communication Power Module-B (BCP-B)
- Battery Management Unit (BAT)(Optional)
- Pressure Unit While Drilling (PWD)
- Electromagnetic Propagation Resistivity-3 (EPR-3)(Optional)
- High Build Rate Rotary Steerable Unit (RSU-B)

*Note: RSU-B includes Azimuthal Gamma Ray*

## Specifications

Tool O.D. (Nominal)	3.375 in.
Hole Size	4-1/2 in. to 5-1/2 in. (114 to 140 mm)
Max. Temperature	350°F (175°C)
Max. Pressure	20,000 psi (137.9 MPa)
Length (Nominal)	39 ft.-6.8 in. (12.06 m)
Weight	1,985 lbs. (900 kg)
Connections	Up:2 3/8 in. IF Box Down:2 3/8 in. Reg Box
Dogleg Severity	Max Rotating 30°/100 ft. (30°/30 m) Max Sliding 45°/100 ft. (45°/30 m)
Mud Flow Range	80-160 GPM

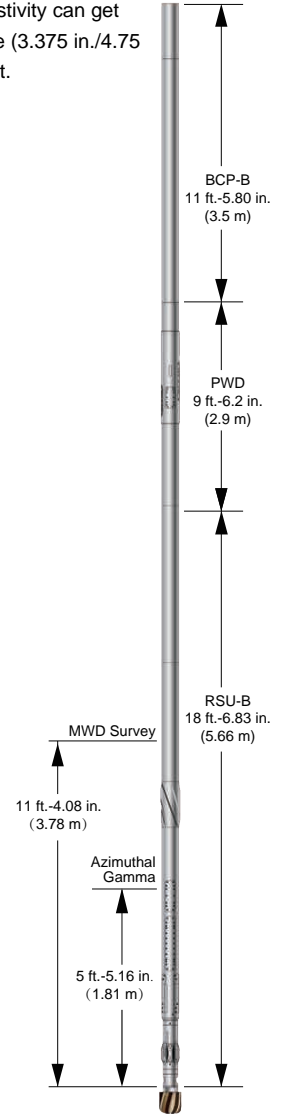



## Applications

- Geosteering
- Automatically steering while drilling
- Well trajectory monitoring
- Provides Resistivity
- Provides Borehole Pressure and Caliper

## Benefits

- Continuous steering while rotating
- Minimized torque & drag
- Improved hole cleaning
- Higher ROP
- Reduced differential sticking
- Bit selection for performance
- Improved hole quality
- Time saving

## Features

- Build rate is 6.5°/100 ft (6.5°/30 m).
- Provides Azimuthal Gamma Ray
- Provides Near Bit Inclination.

## Introduction

Geosteering with near bit inclination, azimuthal gamma ray and resistivity can get information for reservoir navigation. Adopt insert mode, different size (4.75 in./6.75 in./9.5in.) instrument can share insert probe, reduce the cost.

## Components

Stop SubBi-directional Communication Power Module-B (BCP-B)  
 Battery Management Unit (BAT)(Optional)  
 Pressure Unit While Drilling (PWD)(Optional)  
 Wireless Measurement While Drilling-B (MWD-B)  
 Electromagnetic Propagation Resistivity-B (EPR-B)(Optional)  
 High Build Rate Rotary Steerable Unit (RSU-B)

*Note: MWD-B includes Azimuthal Gamma Ray*

## Specifications

Tool O.D. (Nominal)	8.25 in. / 9.5 in. tools with 9.5 in. RSU.
Hole Size	12 in. to 17-1/2 in. (305 mm to 445 mm)
Max. Temperature	350°F (175°C)
Max. Pressure	20,000 psi (137.9 MPa)
Length (Nominal)	40 ft.-3.46 in. (12.28 m)
Weight	14,330 lbs. (6500 kg)
Connections	Up: 7-5/8 in. Reg Box Down: 7-5/8 in. Reg Box
Dogleg Severity	Max Rotating 6.5°/100 ft. (6.5°/30 m) Max Sliding 13°/100 ft. (13°/30 m)
Mud Flow Range	300-1600 GPM

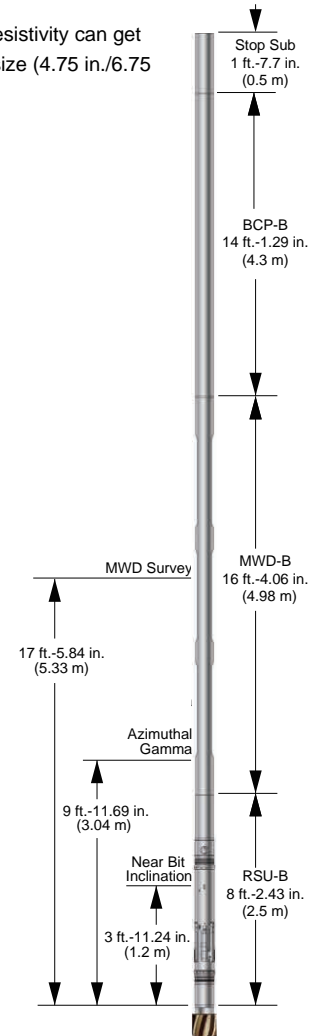



## Applications

- Precise reservoir navigation
- Exact wellbore placement
- Early detection of bed boundaries
- Geo-confirmation of sedimentary structures
- Offers a smooth wellpath and excellent hole quality for faster completions and enhanced production.
- Identifies hole cleaning problems and fluid influx into the wellbore.
- Optimizes drilling performance and reliability
- Increased Rate Of Penetration (ROP)

## Benefits

- Continuous steering while rotating
- Minimized torque & drag
- Improved hole cleaning
- Higher ROP
- Reduced differential sticking
- Bit selection for performance
- Improved hole quality
- Time saving

## Introduction

RSU-B is based on closed-loop systems with new designed MWD technique. It allows steering to target by advanced directional control methods in most challenging wellbore trajectories. Adds any LWD tools or borehole optimization systems into integrated BHA follow application needs.

Used in conjunction with near bit azimuth gamma, the rotary steering unit can measure real-time near bit inclination and near bit azimuth data, achieving 3D trajectory steering control.

## Specifications

Tool O.D.	3.375 in.	4.75 in.	6.75 in.	9.5 in.
Max. Operating Temperature	350°F (175°C)			
Max. Working Pressure	20000 Psi (137.9 MPa)			
Build Rate	30°/100 ft. (30°/30 m)	10°/100 ft. (10°/30 m)	15°/100 ft. (15°/30 m)	6.5°/100 ft. (6.5°/30 m)
Near Bit Inclination	0-180°			
Accuracy	±0.1°			
Near Bit Azimuth	0-360°			
Accuracy	±1.0°			

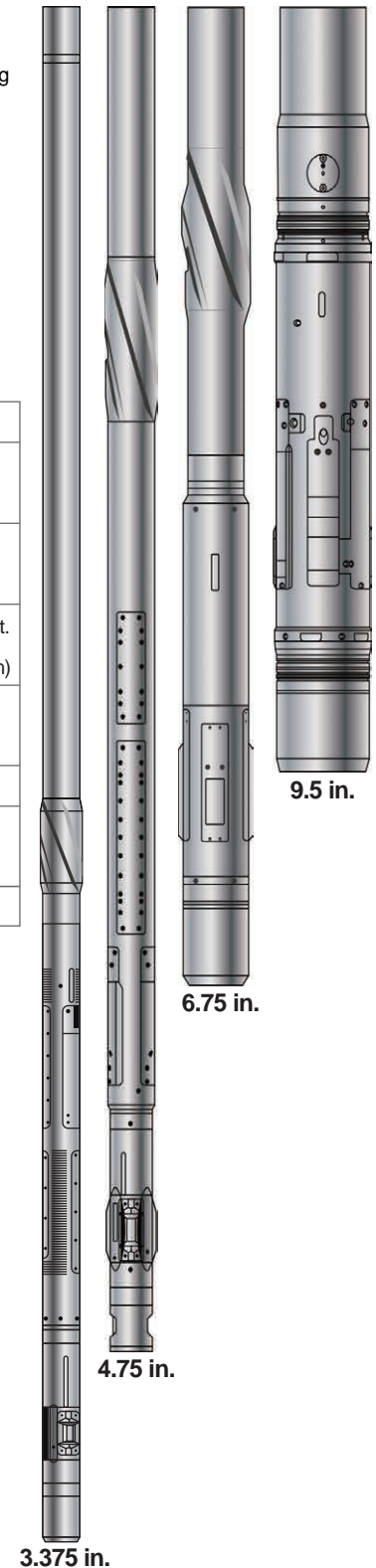



## Applications

- Steering drilling systems for re-entry and horizontal wells.
- Directional control
- Relief well drilling
- Precision geosteering in high angle wells.

## Benefits

- Automated directional control
- Improved horizontal TVD control
- Reduced hole tortuosity
- Azimuthal kick off mode

## Features

- Adopt insert mode, different size (3.375 in./4.75 in./6.75 in./8.25 in./9.5 in.) instrument can share circuit, reduce the cost.
- Azimuthal gamma ray confirmation formation boundaries and orientation, guides directional drilling operations better

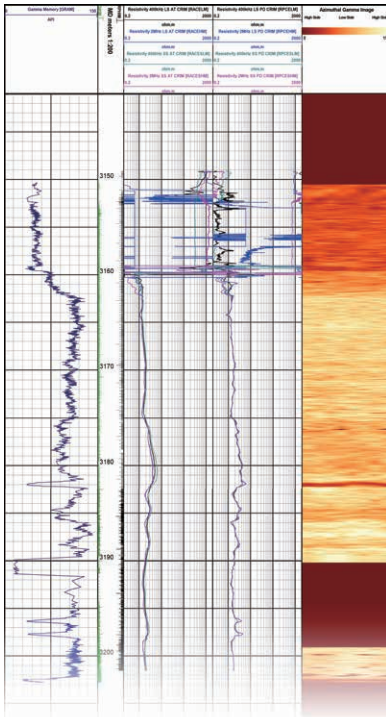

## Specifications

Measurement	Range	Resolution	Accuracy
Inclination	0°-180°	0.1	± 0.15°
Azimuth	0°-360°	0.35	±1.0 @ INC>10°
Toolface	Magnetic	0°-360°	± 1.5°
	Gravty	0°-360°	± 1.5°
Temperature	50°F - 300°F, 350°F optional	1.1	± 3.0°C
Total Magnetic Field	30,000-66,000 gamma	100	± 200
Transmission Rates	0.4 bit/s ~ 2 bits/s Pulse Width Selectable: 3.0/2.0/1.5/1.0/0.8/0.5/0.36/0.32/0.24 sec		
Directional Probe OD	1.75 in.		
Max. Temperature	350°F (175°C)		
Max. Pressure	20000 Psi (137.9 MPa)		
MTF/GTF Switching, Inclination Degrees: MTF/GTF Switching, Operator Selectable (default set at 3°) Inclination Degrees			
<b>Vibration Measurement</b>			
Sensor Type	Axial Vibration	One Accelerometer, Z direction	
	Lateral Vibration	Two Accelerometers, X-Y direction	
Acceleration Range	0-15 g		
Frequency Range	0-82 Hz		
Realtime Log Options	Lateral and Axial vibration; Transmitted as severity level (scaled to g-RMS)		
Post Run/Memory Log Options	Average & Max. lateral and axial vibration in g-RMS and as severity level		
<b>Rotation &amp; Stick-Slip Measurement</b>			
Sensor Type	Two Axis Magnetometer		
Rotation Speed	0-±1000 RPM		
Accuracy	±1%		
Realtime Log Options	Downhole RPM, Stick-Slip transmitted as severity level		
Post Run/Memory Log Options	Min., Max., & Average RPM, Stick-Slip & Backward Rotation severity		
<b>Azimuthal Gamma Ray Specifications</b>			
Sensor Type	Scintillation		
Measurement	API GR		
Real Time	Yes		
Recorded	Yes		
Range	0-500 API		
Section Quantity	8		
Accuracy	±3% of full scale		
Statistical Repeatability	±3 API @ 100 API and ROP=60 ft./hr		
Vertical Resolution	6 in.		

## Applications

- Provides formation resistivities
- Provide realtime formation evaluation services.
- Provide wellbore placement
- Improve geosteering capabilities
- Operates at frequency of 2 MHz and 400 kHz Compensated antenna design with dual spacing transmitter pairs.

## Features

- 8 quantitative resistivities with separate depths of investigation works in all mud types.
- Adopt insert mode, different size (4.75 in. /6.75 in.) instrument can share insert probe, reduce the cost.

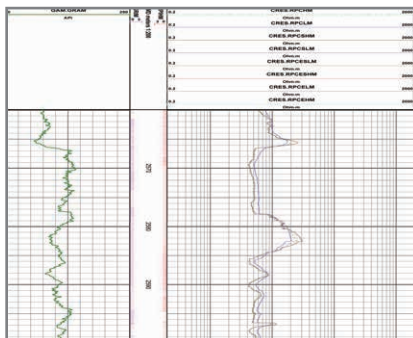

## Introduction

EPR-B transmits electromagnetic waves into the formation and measures the changes in the physical characteristics of the returned electromagnetic waves. The changes in the physical characteristics of the electromagnetic waves indicate the formation resistivity.

## Specifications

Tool O.D.		4.75 in. / 6.75 in./ 8.25 in.	
Max Operating Temp		350°F (175°C)	
Max Working Pressure		25000 Psi (172.4 MPa)	
2 MHz	Phase Difference	Range	0.1-3000 ohm-m
		Accuracy	± 1% (0.1-50 ohm-m); ±0.5 mmho/m (> 50 ohm-m)
	Attenuation	Range	0.1-500 ohm-m
		Accuracy	± 2% (0.1-25 ohm-m); ±1.0 mmho/m (> 25 ohm-m)
		Vertical Resolution	8 in. (203 mm)
400 kHz	Phase Difference	Range	0.1-1000 ohm-m
		Accuracy	± 1.0% (0.1-25 ohm-m); ±1.0mmho/m (>25 ohm-m)
	Attenuation	Range	0.1-200 ohm-m
		Accuracy	± 5.0% (0.1-10 ohm-m); ±5.0mmho/m (>10 ohm-m)
		Vertical Resolution	12 in. (304 mm)







## Applications

- Transmission of downhole data to surface.
- Transmission of surface commands to downhole.

## Features

- Long working time without replacing battery under generator mode

## Introduction

Bi-directional Communication Power Module-B (BCP-B) and downlink devices (SDD-II, NPG). The BCP-B (Bi-Directional Communication & Power Module-B) is capable of generating 300 Watt power output, providing 33 Vdc to the HbuildLWD system, providing circuit breaker protection for upper and lower mounted instruments, detecting downlink data by monitoring turbine speed, transmitting data to the surface via a pulser. It can be installed in any position of the instrument string, which provides a lot of conveniences for the logging.

Using the insert mode in the center of the drill collar. The electronic circuit and sensor can be applied to drill collars of different sizes (3.375 inch, 4.75 inch, 6.75 inch and 9.5 inch) only by configuring centralizers of different sizes.

The SDD-II ends commands from the surface to downhole instrument by controlling the NPG (Negative Pulse Generator) which controls the mud flow.

## Specifications

Tool O.D.	3.375 in.	4.75 in.	6.75 in.	8.25 in.	9.5 in.
Make-up Length	11.48 ft. (3.5 m)	12.14 ft. (3.7 m)	10.50 ft. (3.2 m)	10.50 ft. (3.2 m)	14.11 ft. (4.3 m)
Weight	321 lbs. (145 kg)	708 lbs. (320 kg)	1,128 lbs. (510 kg)	1,274 lbs. (576 kg)	1,900 lbs. (860 kg)
Flow Range	80-160 gpm	125-350 gpm	200-900 gpm	300-1600 gpm	300-1600 gpm
Max. Temperature	350°F (175°C)				
Max. Pressure	20,000 psi (137.9 MPa)				
Max. Turbine RPM	5000				
Output	33 Vdc±1				
Max. Power Output	300 Watts				



Safe Direction Drilling Panel-II (SDD-II)

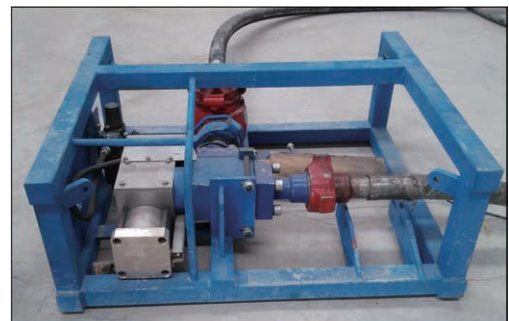

Negative Pulse Generator (NPG)

## Applications

- Flow-off directional surveys
- Directional surveys connected downhole motor on BHA top

## Introduction

The Battery Management Unit provides directional sensor power during flow-off, acquire survey data, and store the data. Transmit the survey data to surface after flow-on.

## Specifications

Maximum Temperature	350°F (175°C)
Maximum Pressure	20,000 psi (137.9 MPa)
Outside Diameter	3.375 in. ( 85.7 mm)
	4.75 in. (120.7 mm)
	6.75 in. (171.5 mm)
	8.25 in. (209.5 mm)
Length	4.93 ft. (1.5 m)
Connections	GVT2 Box Up
	GVT2 PIN Down



## Applications

- Conductive to the control of well safety
- Optimizing the acquisition period
- Minimizing the total time required to accurately measure annular pressure

## Introduction

PWD can accurately detect the annular pressure, the borehole pressure and temperature. Used to judge the underground complex situation, such as well leakage, blowout, well inflow and monitoring well, and conducive to the control of well safety.

## Specifications

Tool O.D.	4.75 in. / 120 mm	6.75 in. / 172 mm	8.25 in./210 mm
Max. Pressure	20000 psi (137.9MPa)/25000 psi (172 MPa) (option)		
Max. Temperature	300°F (150°C)/350°F (175°C) (option)		
Length	5 ft.-6.93 in. (1.7 m)	4 ft.-3.18 in. (1.3 m)	4 ft.-8 in. (1.424 m)
Flow range	160-320 gpm	300-675 gpm	400-900 gpm
Data Acquisition Type	Real-time & Downhole Record		
Data Transmit Type	Data Transmit Type Positive pulse		
Pressure Measurement Range	0 - 25000 psi		
Accuracy	Accuracy ± 0.25% full scale		

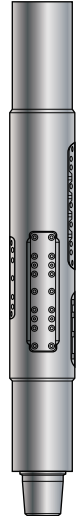



## Features

- Accurate downhole measurement of equivalent circulating density.
- Swab/surge pressure monitoring while tripping and reaming.
- Accurate downhole measurement of hydrostatic pressure and effective mud weight.
- Accurate measurement of caliper by ultrasonic.

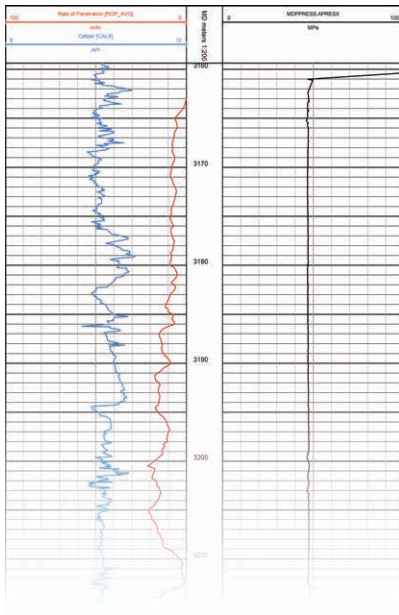

## Introduction

PCD can accurately detect the annular pressure, the caliper, the borehole pressure and temperature. It is used to judge the underground complex situation, such as well leakage, blowout, well inflow and monitoring well, and conducive to the control of well safety.

## Specifications

Tool O.D.	4.75 in.	6.75 in.	8.25 in.
Max Pressure	20,000 psi (137.9 MPa)		
Maximum Temperature	300°F (150°C)		
Make-up Length	6 ft.-2.8 in. (1.9 m)		
Operating Time	Real-time/ No limited		
Data Acquisition Type	Real-time & Downhole Record		
Pressure Measurement Range	0-25000 psi		
Caliper Measurement Range	5.30 in. to	7.30 in. to	8.80 in. to
	7.30 in.	9.30 in.	10.80 in.
	(135 mm to 185 mm)	(185 mm to 236 mm)	(224 mm to 274 mm)
Caliper Accuracy	±0.2 in. (± 5 mm)		
Sensor Type	Ultrasonic detector		
Measurement	Pressure & Caliper		
Real Time	Yes		
Recorded	Yes		



## Applications

- ECD/Monitor Real-time ECD
- Improve hole cleaning
- Monitor status of liquid leaking to formation
- Monitor hole erosion
- Judge Bit working Condition

## Introduction

This tool can measure weight on bit (WOB), BHA Torque, Hole Pressure and annular pressure, and transmit to surface via positive pulse. According the sensor data, drilling operator can modify the drilling parameter, mud equivalent circulation density, and drill safely and quickly.

## Specifications

Maximum Temperature	350°F (175°C)	
Maximum Pressure	20,000 psi (137.9 MPa)	
OD	6-3/4 in. (172 mm)	
Connector	Up	GVT2 PIN
	Down	GVT2 BOX
Dogleg	16°/30 m @ sliding	
	9°/30 m @ rotation	
Power	Alternator	
Wob Measure Range	± 300 KN	
Wob Measure Accuracy	± 5%	
Torque Measure Range	± 30 KNm	
Torque Measure Accuracy	± 5%	
Pressure Measure Range	0~25000 psi	
Pressure Measure Accuracy	± 0.3% full range	





# Caliper Corrected Neutron Porosity- Rotary Azimuthal Density-4.75 (CCN-RAD-4.75)

**Geo-Vista**

## Applications

- Accurate, real-time quantification of porosity and gas identification for saturation calculations.
- Reservoir Navigation using high-resolution imaging and gas-oil/water identification in real-time.
- Wellbore stability analysis using azimuthal caliper and density imaging in real-time.
- Structural formation dip analysis and updating reservoir models from density imaging.

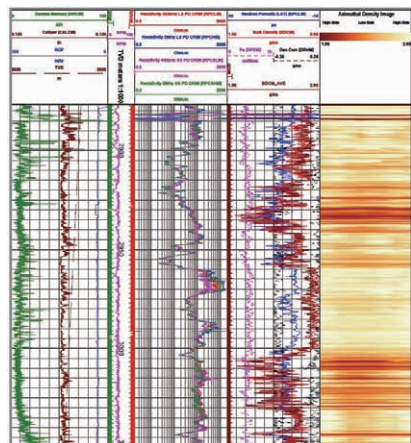
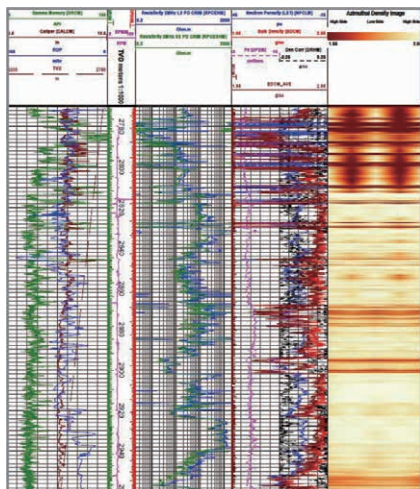

## Introduction

CCN-RAD offers measurement of formation density, neutron porosity, borehole caliper, and formation imaging. That provides geosteering for maximum reservoir exposure. Neutron porosity and bulk density are critical for the quantification of hydrocarbons in the reservoir.

## Specifications

Diameter	4.75 in. With 5.59 in. upset
Max. Pressure	20000 psi (137.9 MPa)
Max. Temperature	300°F (150°C)
Weight	1100 lbs. (498 kg) (CCN-RAD 4)
Max. Dogleg Severity	15°/100 ft. (15°/30 m) Rotating 30°/100 ft. (30°/30 m) Sliding
<b>CCN</b>	
Service	Formation Porosity
Tool Type	Caliper Corrected Neutron
Detectors	Lithium-6 Iodide Crystal with Photomultiplier tube for both Near and Far detectors
Porosity Accuracy	0.5 pu below 10 pu, 5% of reading for 10-50 pu
Vertical Resolution	24 in. (61 cm)
Statistical Repeatability	± 0.6 pu@20 pu @ 200 ft./hr.
Max. Logging Speed	180 ft./hr (@2 points/ft.)
Depth Of Investigation	10 in. estimated for 8.5 in. 10 pu borehole
Radioactive Source	Am 241-Be Strength: 5 Curies (185 GBq)
Measure Point	4.6 ft. (1.4 m) (From downhole tool end)
Voltage	30 Vdc
Current Draw	160-170 mA
<b>RAD</b>	
Service	Formation Bulk Density Service with Hole Caliper
Tool Type	Rotational Azimuthal Density
Detectors	Nal Scintillation Crystal with photomultiplier tube for both Long and Short Spaced detectors
Density Specifications	
Range	1.6-3.1 g/cc
Accuracy	± 0.025 g/cc@200 ft./hr (60 m/hr) and 2.5 g/cc
Statistical Repeatability	18 in. (45 cm) (full resolution)
Downhole End Measure Point	5.1 ft. (1.5 m)
Photoelectric Factor Specifications	
Range	1-10 Barnes/electron (B/e)
Accuracy	± 0.25 B/e from 2-5 B/e
Statistical Repeatability	± 0.25 B/e@200 ft./hr (60 m/hr)
Vertical Resolution	6 in. (150 mm) (full resolution)
Downhole End to Pe Measure Point	5.1 ft. (1.5 m)
Acoustic Standoff Caliper Specifications	
Range	0-2 in. (Out of housing)
Accuracy	±0.075 in. (0 to 0.5 in.) ±0.125 in. (0.5 to 1.0 in.) ±0.25 in. (1.0 to 2.0 in.) Out of housing
Max. Logging Speed	180 ft./hr (@2 points/ft.)
Radioactive Source	Cs137 Strength: 2 Curies (74 GBq)
Voltage	30 V
Current Draw	350 mA-390 mA



## Applications

- Accurate, real-time quantification of porosity and gas identification for saturation calculations.
- Reservoir Navigation using high-resolution imaging and gas-oil/water identification in real-time.
- Wellbore stability analysis using azimuthal caliper and density imaging in real-time.
- Structural formation dip analysis and updating reservoir models from density imaging.

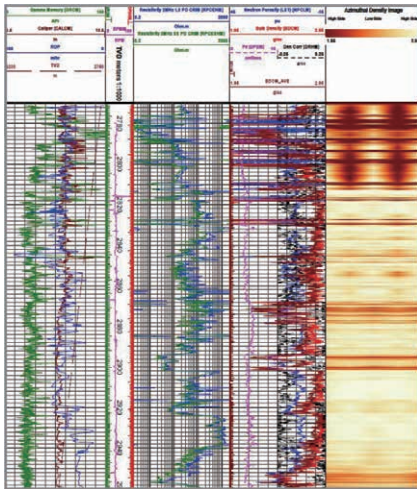

## Introduction

CCN-RAD offers measurement of formation density, neutron porosity, borehole caliper, and formation imaging. That provides geosteering for maximum reservoir exposure. Neutron porosity and bulk density are critical for the quantification of hydrocarbons in the reservoir.

## Specifications

Diameter	6.75 in. with 7.50 in. upset	8.25 in. With 10.125 in. upset
Max. Pressure	20000 psi (137.9 MPa)	
Max. Temperature	300°F (150°C)	
Weight	893 lbs. (405 kg)	1325 lbs. (600 kg)
Service	Formation Porosity	
Tool Type	Caliper Corrected Neutron	
Dogleg Severity	9°/100 ft. (9°/30 m) Rotating	6.5°/100 ft. (6.5°/30 m) Rotating
	16°/100 ft. (16°/30 m) Sliding	12°/100 ft. (12°/30 m) Sliding
Detectors	Lithium-6 Iodide Crystal with Photomultiplier tube for both Near and Far detectors	
Porosity Accuracy	0.5 pu below 10 pu, 5% of reading for 10-50 pu	
Vertical Resolution	24 in. (61 cm)	
Statistical Repeatability	± 0.6 pu @ 20 pu @ 200 ft./hr.	
Max. Logging Speed	180 ft./hr (@2 points/ft.)	
Depth Of Investigation	10 in. estimated for 8.5 in. 10 pu borehole	
Radioactive Source	Am 241-Be Strength: 5 Curies (185 GBq)	
Measure Point	4.6 ft. (1.4 m) (From downhole tool end)	
Voltage	30 Vdc	
Current Draw	160-170 mA	

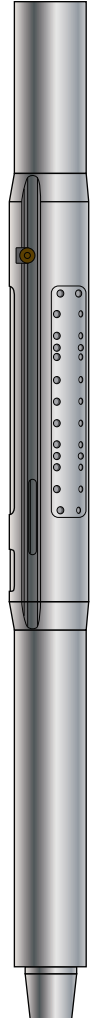

## Applications

- Accurate, real-time quantification of porosity and gas identification for saturation calculations.
- Reservoir Navigation using high-resolution imaging and gas-oil/water identification in real-time.
- Wellbore stability analysis using azimuthal caliper and density imaging in real-time.
- Structural formation dip analysis and updating reservoir models from density imaging.
- 8 or 16 sector azimuthal density, Pe and borehole caliper measurements.

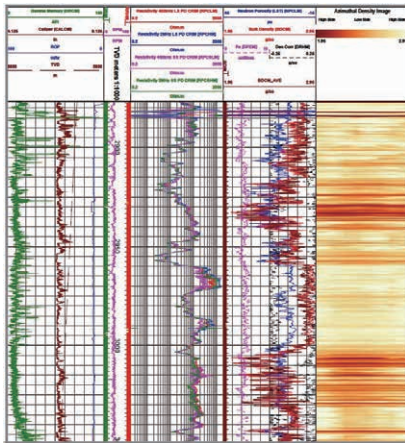

## Introduction

CCN-RAD offers measurement of formation density, neutron porosity, borehole caliper, and formation imaging. That provides geosteering for maximum reservoir exposure. Neutron porosity and bulk density are critical for the quantification of hydrocarbons in the reservoir.

## Specifications

Diameter	6.75 in.	8.25 in.
Max. Pressure	20000 psi (137.9 MPa)	
Max. Temperature	300°F (150°C)	
Weight	1092 lbs. (495 kg)	1945 lbs. (881 kg)
Service	Formation Bulk Density Service with Hole Caliper	
Tool Type	Rotational Azimuthal Density	
Max. Dogleg	Rotating	9°/100 ft. (9°/30 m)
Severity	Sliding	16°/100 ft. (16°/30 m)
		12°/100 ft. (12°/30 m)
Detectors	NaI Scintillation Crystal with photomultiplier tube for both Long and Short Spaced detectors	
<b>Density Specifications</b>		
Range	1.6-3.1 g/cc	
Accuracy	± 0.015 g/cc	
Statistical Repeatability	± 0.025 g/cc@200 ft./hr (60 m/hr) and 2.5 g/cc	
Vertical Resolution	18 in. (45 cm) (full resolution)	
Downhole End Measure Point	5.1 ft. (1.5 m)	
<b>Photoelectric Factor Specifications</b>		
Range	1-10 Barnes/electron (B/e)	
Accuracy	± 0.25 B/e from 2-5 B/e	
Statistical Repeatability	± 0.25 B/e@200 ft./hr (60 m/hr)	
Vertical Resolution	6 in. (150 mm) (full resolution)	
Downhole End to Pe Measure Point	5.1 ft. (1.5 m)	
<b>Acoustic Standoff Caliper Specifications</b>		
Range	0-2 in. (Out of housing)	
Accuracy	±0.075 in. (0 to 0.5 in.)	
	±0.125 in. (0.5 to 1.0 in.)	
	±0.25 in. (1.0 to 2.0 in.) Out of housing	
Max. Logging Speed	180 ft./hr (@2 points/ft)	
Radioactive Source	Cs137 Strength: 2 Curies (74 GBq)	
Voltage	30 V	
Current Draw	350 mA~390 mA	

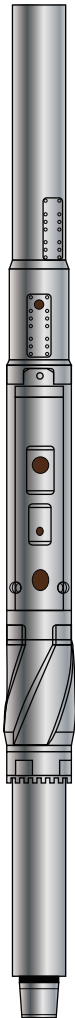





## Applications

- For geosteering, the distance to the layer interface can be inferred to enhance the reliability and accuracy of geosteering.
- The azimuth resolution of 16 sectors close to the ground can be obtained. Its dynamic compensation can eliminate environmental interference.
- The 4 3/4" ARD and 6 3/4" ARD are compatible with HbuildLWD tools. This combination of drilling tools can accurately control the steering during drilling in complex formations.

## Benefits

- Deeper detection radius, the approaching stratum can be warned in advance to make timely decisions.
- The 16-sector azimuth resolution can determine the azimuth angle close to the formation and avoid entering shale or other hard formations.
- Improve the rate of oil reservoir drilling.
- The oil-water interface can be clearly distinguished from the inclined top layer of shale.
- Suitable for all types of mud.

## Features

- ARD eliminates environmental influences to a great extent, such as wellbore size, tool eccentricity, tool bending degree and temperature.
- The multiple coil system makes the tool more sensitive to detection near the ground.
- The rectangular coil receiver enhances the detection depth of ring waves.

## Introduction

ARD determines the azimuth angle close to the formation interface in real-time, such as the azimuth angle of the shale lens, cap layer or oil-water interface. The detection radius from the borehole axis is up to 17 feet (5.2 m). ARD is used for water-based mud, synthetic-based mud or oil-based mud.

## Specifications

Tool O.D.	4 3/4 in. (121 mm) / 6 3/4 in. (172 mm)
Applicable borehole size	5 7/8 in.-6 3/4 in. / 8 3/8 in.-10 5/8 in.
Common borehole size	6 1/8 in. (156 mm) / 8 1/2 in. (216 mm)
Tool length	11.03 ft. (3.36 m)
Tool weight	672 lbs (305 kg) / 1274 lbs (578 kg)
Equivalent stiffness ODxID	4.755 in.x2.165 in. / 6.755 in.x2.165 in.
Type of cut-off sub upper connector	NC38 / NC50 Female thread
Type of connector	GT4 / GT6
Operating specifications and restrictions	
Displacement limited by LWD	125-350 gpm / 200-900 gpm
Maximum pull	534 klbs (2376kN) / 704 klbs (3132 kN)
Maximum bending torque	
Rotating	7 kft-lbs (10 kNm) / 20 kft-lbs (27 kNm)
Sliding	16 kft-lbs (22 kNm) / 61 kft-lbs (82 kNm)
Maximum temperature	300°F (150°C)
Maximum pressure	20000 psi (1378 bar)
Sensor Specifications	
Distance between measuring point and tool bottom	5.46 ft. (1.66 m)
Detection boundary	17 ft. (5.2 m)
Statistical repetition rate	±2%
Vertical resolution	24 in. (61 cm) (High resolution)
Azimuth quadrant	16

2 MHz	Phase Difference	Range	0.1-3000 ohm-m
		Accuracy	± 1% (0.1-50 ohm-m) ±0.5 mmho/m (> 50 ohm-m)
	Attenuation	Range	0.1-500 ohm-m
		Accuracy	± 2% (0.1-25 ohm-m) ±1.0 mmho/m (> 25 ohm-m)
Vertical Resolution		8 in. (203 mm)	
400 kHz	Phase Difference	Range	0.1-1000 ohm-m
		Accuracy	± 1.0% (0.1-25 ohm-m) ±1.0 mmho/m (>25 ohm-m)
	Attenuation	Range	0.1-200 ohm-m
		Accuracy	± 5.0% (0.1-10 ohm-m) ±5.0 mmho/m (>10 ohm-m)
		Vertical Resolution	12 in. (304 mm)



## Applications

- Optimize mud-weight selection
- Predict pore pressure independent of temperature and salinity effect.
- Identify top-of-cement
- Understand rock mechanical properties
- Measure porosity sourceless
- Position bit-on-seismic using synthetics
- Identify gas influx or formation gas.
- Perform many other standard sonic applications.

## Introduction

Acoustic While Drilling (AWD) provides real-time compressional and shear wave travel-time measurements in slow and fast formations. Shear and compressional slowness with computed semblance values are acquired using a state-of-the-art acoustic source combined with multiple arrays of receivers. Advanced downhole processing and waveform stacking techniques ensure reliable and fully compensated measurements.

## Specifications

Diameter		4.75 in.	6.75 in.
Tool O.D.		4.82 in. (122.43 mm)	6.9 in. (175.26 mm)
Hole Size		5.625 in. to 8 in. (143 to 203 mm)	8.5 in. to 10.625 in. (216 mm to 270 mm)
Max. Operating Temperature		300°F (150°C)	
Max. Operating Pressure		20,000 psi (137.9 MPa)	
Length		30 ft. (9 m)	23.8 ft. (7.254 m)
Weight		1,760 lbm (798 kg)	2,500 lbm (1,134 kg)
Thread	HbuildLWD	GT4 box up/ GT4 pin down	GT6 box up/ GT6 pin down
	ComLWD	NC38 box up/ NC38 pin down	NC46 box up/ NC46 pin down
Connections			
Makeup Torque		8845 ft.-lbf (11,984 N.m)	25,000 ft.-lbf (33,895 N.m)
Max. Dogleg Severity	Rotating	15°/100 ft. (15°/30 m)	8°/100 ft. (8°/30 m)
	Sliding	30°/100 ft. (30°/30 m)	16°/100 ft. (16°/30 m)
Max. Flow Rate		400 gal US/min. (1,514 L/min.)	800 gal US/min. (3,028 L/min.)
Max. Sand Content		3%	
Max. LCM Size		0.63 in. (16 mm)	
Average Inertia		62 in.	
Transmitters Number		1	
Receivers Number		4	
Measurement Type		Compression Wave & Shear Wave	
Accuracy, us/ft. (us/0.305 m)		± 1	
Measurement Range		All tools 40-230 us/ft. dependent on mud type	
Max. Shock		250 g for 100,000 cycles	
Measure Point From Tool Bottom		14 ft. (4.267 m)	





## Applications

- Fracture characterization
- Borehole breakouts and geomechanics
- Borehole geometry evaluation
- Thin-bed identification
- Structural dip determination
- Lithology and porosity variations
- Secondary porosity identification
- Sedimentary features identification

## Features

- Measures both Amplitude and Travel Time to obtain fully sampled images of the borehole surface.
- Enables client to evaluate borehole quality
- Enables a 256 sector circumferential resolution (1.4°) which is sufficient to fully sample the borehole wall in the typical ROP and RPM ranges experienced while drilling

## Benefits

- High quality ultrasonic acoustic transducer
- 3D Borehole image visualization
- High sampling rate

## Introduction

Ultrasonic Imaging While Drilling (UID) provides high-resolution borehole images while drilling in OBM/WBM.

Borehole imaging has been used to calculate borehole caliper, stress, breakout orientation, stratigraphic and geologic structure imaging in conventional wells. Borehole wall images are commonly used for fracture characterization during well planning to optimize hydraulic stimulation and maximize the possible return from a reservoir.

The image service is only available in memory mode while drilling, caliper is in real-time.

## Specifications

Maximum Temperature	300°F (150°C)
Maximum Pressure	20,000 psi (137.9 MPa)
Tool Size	6-3/4 in. (172 mm)
Hole Size	8-3/8 to 10 in. (213 mm to 254 mm)
Tool Weight	825 lbs. (375 kg)
Tool Length	8.8 ft. (2.68 m)
Logging Speed	Up to 400 ft./hr
Mud Type	OBM/WBM
Maximum Mud Weight	16 ppg
Azimuthal Sectors	256



## Applications

- Continuous, real-time, lithology-independent porosity without chemical sources.
- Resistivity-independent pay identification.
- Continuous, real-time permeability evaluation.
- Thin-bed characterization.
- Carbonate facies characterization.
- Irreducible water saturation.
- Gas-bearing reservoir evaluation.
- Heavy oil and tar identification.
- Hole size distribution

## Introduction

By providing lithology-independent porosity, pore-size distribution, continuous permeability and direct hydrocarbon detection, the MRI delivers a step change in real-time producibility assessment for complex reservoirs.

While drilling a well with a challenging trajectory to target a complex carbonate reservoir the MRI (The high-quality, real-time magnetic resonance) to evaluate rock and fluid properties and obtain accurate lithology independent porosity and continuous permeability to optimize placement of the wellbore, the advanced petrophysical evaluation improved testing and completion design and calculated reservoir producibility for focus on well.

## Specifications

Max. Tool O.D. (Single-sleeve Stabilizer)	6.9 in. (175 mm) (single-sleeve stabilizer)	
Max. Pressure	20,000 psi (137.9 MPa)	
Max. Temperature	300°F (150°C)	
Make-up Length	32.38 ft. (9.87 m)	
Weight	3385.4 lbm. (1535.6 kg)	
Borehole Size Range	8.25 to 10.375 in. (20.96-26.36 cm)	
Normal Collar O.D.	6-3/4 in. (171.5 mm) API tolerance	
Thread Connections	GT6 box up/ GT6 box down	
Vertical Resolution Static	1.5 in./min.-4 in./min. (3.81 cm/min.-10.16 cm/min.)	
Vertical Resolution Dynamic	10 in. @50 ft./h (25.4 cm@15 m/h)-0.25 m/min. 20 in. @100 ft./h (50.8 cm@30 m/h)-0.5 m/min.	
Measurement of Porosity	0-100 pu	
Min. mud Resistivity	0.02 ohm.m	
Shell Diameter	15 in. (381 mm)	
Shell Thickness	0.24 in. (6 mm)	
Max. Number of Echoes	2000	
Min. Echo, Spacing	0.6 ms	
T <sub>2</sub> Distribution	0.5 to 5,000 ms	
Precision	< 10 pu/PAP	
Depth of Investigation	14 in. (356 mm)	
Static Field Gradient	58 gauss	
Freq of Sensitive Volume	245 kHz	
Operating Position	Centralized	
Hole Deviation	Vertical to Horizontal	
Power Supply	Turbine alternator	
Dogleg	Sliding	16°/100 ft. (16°/30 m)
	Rotating	8°/100 ft. (8°/30 m)
Max. System Shock Level	30 min. at shock level 5 (50-gn threshold or accumulated 200,000 shocks above 50 gn)	
Torque	23,500 ft. lbf (31,800 N.m)	
Max. PH	< 9	



## Applications

- Optimization of mud weight
- Selection of optimal case
- Estimation of reserves
- Identification of fluids and their contacts.
- Reservoir model refinement
- Well placement

## Benefits

- Mitigates risk through reservoir pressure management.
- Improves prediction of reserves using fluid typing.
- Enhances drilling performance through optimal mud weight.
- Saves time and cost by eliminating need for tool orientation.

## Features

- Provides formation pressure in drilling environment
- Provides direct pore pressure and mobility data for fluid typing and mud-weight optimization
- Used in any hole orientation—vertical or deviated
- Optimizes pretest volume and drawdown to formation characteristics
- Real-time measurements with quality control indicators

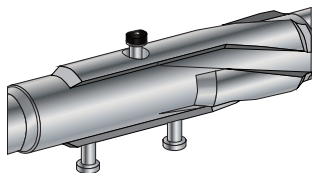

## Introduction

Formation Tester While Drilling (FTD) service makes accurate measurements that provide direct pore pressure and mobility data for fluid typing, reservoir pressure management, and mud-weight control and optimization. It achieves time savings through a focus on operational efficiency and measurement versatility, accuracy, and quality.

## Specifications

		4.75 in.	6.75 in.
<b>Tool Design</b>			
Measurement Type	Probe pretest		
Pressure Gauges	High-precision quartz and strain		
Power Supplies	Battery, MWD turbine power		
<b>Measurement Specifications</b>			
Probe Dimensions	1.75 in. (44.45 mm) OD	2.25 in. (57.15 mm) OD	
	0.44 in. (11.18 mm) ID	0.56 in. (14.22 mm) ID	
Pretest	Volume	0 to 25 cm <sup>3</sup> , fully adjustable	
	Drawdown Rate	0.1 to 2.0 cm <sup>3</sup> /s	
	Delta Pressure	6,000 psi (41 MPa)	>6,000 psi (>41 MPa)
Setting Piston	1.38 in. (35.05 mm)	2.00 in. (50.00 mm)	
Diameter Reach	more than tool OD	more than tool OD	
Memory Capacity	Up to 120 pretests depending on time downhole	80 pretests of 5 min. duration	
Battery Capacity	150 pretests 1 cm <sup>3</sup> /s at 3,200 psi (22 MPa) drawdown at 275 °F (125 °C)		
<b>General Specifications</b>			
Tool Max. O.D.	4.82 in. (122.43 mm)	8.25 in. (209.6 mm)	
	5.75 in. (146.05 mm)	9.25 in. (234.95 mm)	
	5.5 in. (139.7 mm) optional	with optional collar	
Tool Length	40.2 ft. (12.3 m)	31 ft. (9.45 m)	
Weight	2,000 lbm (907 kg)	2,866 lbm (1,300 kg)	
Thread Connections	GT4 box up/ GT4 box down	GT6 box up/ GT6 box down	
Operating Temperature	300 °F (150 °C)		
<b>Mechanical Specifications</b>			
Max. Dogleg Severity	Rotary Mode	15°/100 ft. (15°/30 m)	8°/100 ft. (8°/30 m)
	Sliding Mode	30°/100 ft. (30°/30 m)	16°/100 ft. (16°/30 m)
Axial And Lateral Shocks	10g rms		
<b>Hydraulics</b>			
Max. External Pressure	20,000 psi (138 MPa)		
Flow Range	0 to 400 galUS/min. (0 to 1,514 L/min.)	0 to 800 galUS/min. (3,028 L/min) (standard)	
<i>Note: Specifications are subject to change.</i>			

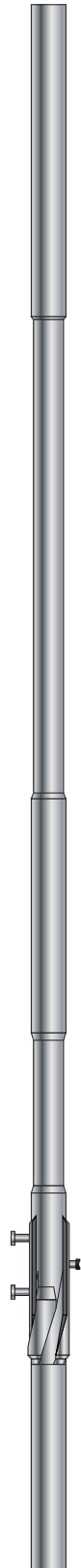



Marketing Manager  
Xujie Zhang  
Mobile: (+86) 13521254100  
Email: zhangxj@renhesun.com

International Sales Manager  
Sharry Liu  
Mobile: (+86) 13911317865  
Email: sharry@renhesun.com

Sales Manager  
Dr. Hong Mei  
Contact: +1 8323585168  
Email: meihong@renhesun.com  
Address: 910 Chinquapin Place,  
Houston, Texas, USA 77094

Product Manager  
Hongai Zhang  
Mobile: (+86) 18911632096  
Email: zhangha@renhesun.com

International Sales Director  
Chen Gang  
Mobile: (+86) 13817367599  
Email: chengang@renhesun.com

Sales Manager  
Chen Hua  
Contact: +971 524515130  
Email: chenhua@renhesun.com  
Address: View 18 Office No. 2102,  
Downtown Jabel Ali, Dubai, UAE